

It is a reliable & maintenance free gauge, suitable for liquids in underground and partially underground tanks.

Construction & Operation :

Analog Indicator - It consists of a float, clamped to a SS wire rope, the other end of which is wound on a drum, carrying constant torque spring housed in IP66 enclosure, to maintain the rope under tension. Due to change in liquid level, the float rises or falls and rotates the drum. This motion is transmitted through a gear mechanism to a pointer moving over a calibrated dial to display level in meters. Two adjustable switches with or without 4-20mA transmitter can be provided optionally.

Digital Indicator - The construction is similar to analog except, constant torque spring is housed in Ex-d enclosure and the gear motion induces a change in variable voltage signal to give 4-20 mA output & digital level indication in %, mm, cm or mtrs. The current output can be further connected to PLC/DCS through current isolator.

Salient Features :

- Easy to install
- Suitable for locations having limited headroom
- Can be retrofitted on existing tanks
- Choice of analog (IP66) & digital (Ex d Gr IIB) indicator
- Choice of max. two alarm switches & transmitter (analog)

Analog Indicator with IP66 Enclosure

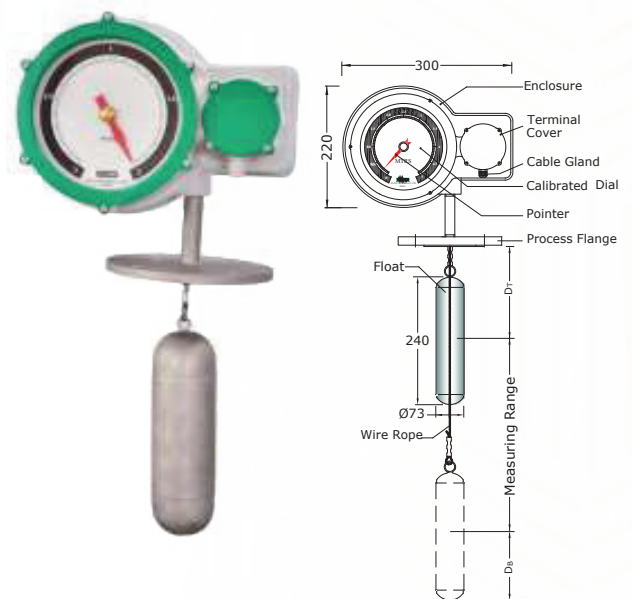

Fig.-1

Digital Indicator with Ex-d IIB Enclosure

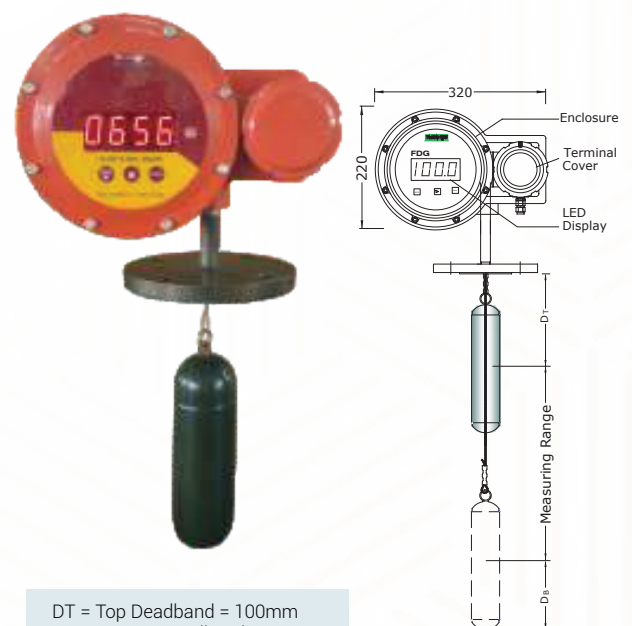

Fig.-2

DT = Top Deadband = 100mm
DB = Bottom Deadband = 150mm
based on water (sp. gr. = 1)

Specifications

General

Installation	: Top
Process Conn. Size	: 3"NB ANSI 150# or 4"NB (with stillwell)
Process Conn.MOC	: CS,SS304/316, PP, ECTFE (Hallar) ctd SS316
Wire Rope	: Ø 1.6 x SS304/316/316L, PTFE insulated SS316
Float MOC	: SS304/ 316/316L, ECTFE (Hallar) SS316
Float Size	: Ø73 x 240H cylindrical
Liquid SG	: ≥ 0.8
Temp Range	: -10 to 100°C
Pressure	: Atmospheric
Indication	: Analog or Digital

Analog Indicator

Ranges	: 0-1, 0-2, 0-3,or 0-10 mtrs
Dial Enclosure	: Cast Al, powder ctd., IP66 protection
Terminal Enclosure	: Cast Al, powder ctd., IP66 protection
Cable Gland	: PG9, Polyamide
Calibrated Dial	: Al, white powder coated with black graduations & numerical
Pointer	: Al, red powder coated
Accuracy	: +/- 50 mm

Adjustable Alarm Switches (Optional)

Switch Type	: Micro switch - SPDT,
Rating	: 5A, 250 VAC
Switch Action	: Mono-stable

Transmitter (Optional)

Supply	: 24 VDC
Output	: 4 - 20 mA (2wire) x 400 Ohms Load
Accuracy	: +/- 2% FS

Digital Indicator

Range	: 0 to 10 mtrs (decimal pt. selectable)
Dial Enclosure	: Cast Al. Ex d Gr IIB
Cable Gland	: ½" NPT, Double Compn, Brass
Display	: 4 digits, 7 segment LED (1")
Programming	: Through keypad
Accuracy	: +/- 2% FS
Supply	: 24 VDC
Output	: 4 -20 mA (4 wire) x 300Ω Load

Accessories :

Still well	: 3"NB pipe, with 4"NB ANSI 150 # flange in CS, SS304/316 or PP
------------	--

Applications :

Raw / Treated Water, Sewage, Effluent, Oil, HDO, LDO & various Solvents

Installation :

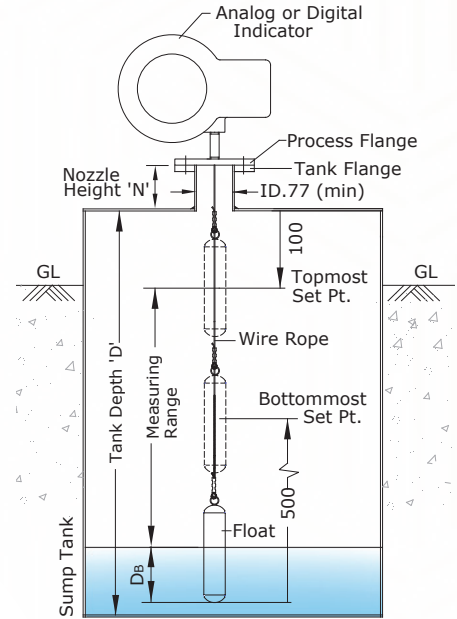

Still well is recommended for turbulent liquids & ranges beyond 5m

Termination & Wiring

Analog Indication

O/P : Two Switches

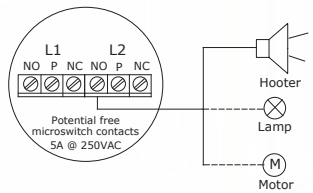

O/P : 4-20 mA

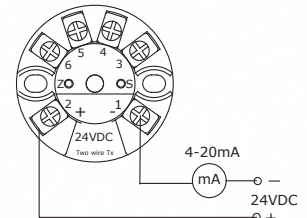

O/P: 2 Switches + 4-20 mA

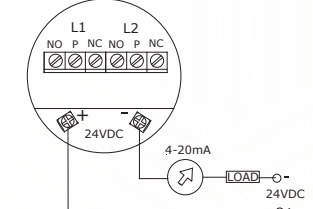

Digital Indication

O/P: 4-20mA

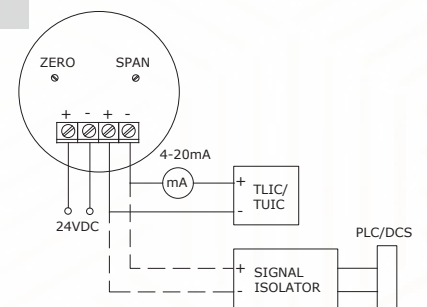

Model Identification

	FDG-							
1. Enclosure Protection x Output								
WP IP66 x Analog Indication	1							
WP IP66 x Analog Indication x 2 switches	2							
WP IP66 x Analog Indication x 4-20 mA	3							
WP IP66 x Analog Indication x 2 Switches x 4-20 mA	4							
WP IP66 x Digital Indication x 4-20 mA	5							
Ex d IIB x Digital Indication x 4-20 mA	6							
2. Installation								
Top		T						
Others		O						
3. Wetted Parts (Float , Wire Rope)								
SS304			N					
SS316			S					
SS316L			L					
ECTFE coated SS316 (3 mtrs max)			V					
Others			O					
4. Process Flange Size								
3" NB ANSI 150#				1				
4" NB ANSI 150# (with stillwell)				2				
Others				0				
5. Process Flange MOC								
CS					M			
SS 304					N			
SS 316					S			
ECTFE ctd SS316					V			
Others					O			
6. Range								
0 - 1 mtrs						1		
0 - 2 mtrs						2		
0 - 3 mtrs						3		
0 - 4 mtrs						4		
0 - 5 mtrs						5		
0 - 6 mtrs						6		
0 - 7 mtrs						7		
0 - 8 mtrs						8		
0 - 9 mtrs						9		
0 - 10 mtrs						10		
7. Stillwell								
Without							W	
CS Stillwell							1	
SS 304 Stillwell							2	
SS 316 Stillwell							3	
PP Stillwell							4	
Others							0	
8. Level Indicator Controller								
Not Provided								W
Techtrol Loop Powered Indicator (LP-Cator)								L
Techtrol Indicator Controller (TLIC)								C
Techtrol Universal Indicator Controller (TUIC)								U

*All dimensions in mm except specified

Ordering Information

Model No, Liquid and its density, Operating Temperature & Pressure, Tank Depth, Nozzle Height, Min/Max Set Points for alarm switches (optional)

PUNE TECHTROL PVT LTD



Regd. & Sales: S-18, MIDC Bhosari, Pune - 411026, India
+91-20-66342900 | ho@punetechtrol.com

Works: J-52/7, MIDC Bhosari, Pune - 411026, India
+91-20-67313600 | www.punetechtrol.com

We Measure the Best for You!

CAT/0075/REV 06/05-21

